

APM SE and SF Series Brushless motor with Copley XTL Xenus Amplifier



Features

- Rated speed from 1000rpm to 3000rpm
- 1kW to 5KW operation
- Commutating Encoder feedback 3000P/R
- Compact (high torque/volume ratio)
- Optimized windings to match Xenus drives for optimum performance and cost

APM-SE

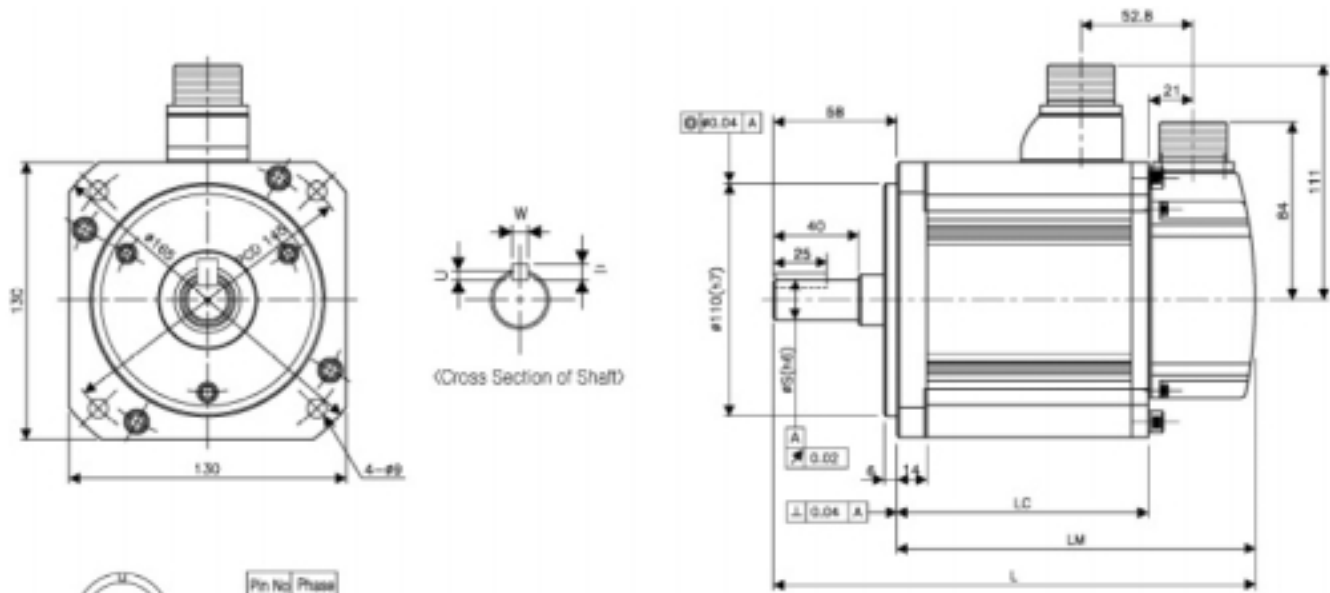

Pin No	Phase
A	U
B	V
C	W
D	Ground



Pin No	Phase	Pin No	Phase
A	A	M	V
B	X	N	V
C	B	P	W
D	R	R	W
E	Z	H	+5V
F	Z	G	0V
K	U	J	SHIELD
L	U		

Model	External Dimension				Key			Weight (kg)
	L	LM	LC	S	T	W	U	
SE09A, SE06D, SE05G, SE03M	202	144	94	19	5	5	3	5.6
SE15A, SE11D, SE09G, SE06M	226	168	118	19	5	5	3	7.2
SE22A, SE16D, SE13G, SE09M	250	192	142	22	6	6	3.5	8.7
SE30A, SE22D, SE17G, SE12M	274	216	166	22	6	6	3.5	10.2

Model	Power Watts	Jm Kgcm ²	Kt Nm/Arms	Ke V/krpm	R	L mH	Tc Nm	Rated Speed rpm	Maximum rpm
SE09A	900	6.7	0.609		0.89	7.8	2.86	3000	5000
SE15A	1500	12.2	0.605		0.41	4.1	4.77	3000	5000
SE22A	2200	17.7	0.607		0.23	2.5	7.0	3000	5000
SE30A	3000	23.1	0.576		0.15	1.8	9.55	3000	5000
SE06D	600	6.7	0.757		1.55	12.9	2.86	2000	3000
SE11D	1100	12.2	0.871		0.77	7.7	5.25	2000	3000
SE16D	1600	17.6	0.858		0.47	5.2	7.63	2000	3000
SE22D	2200	23.1	0.88		0.30	3.8	10.5	2000	3000
SE05G	450	6.8	0.757		1.55	12.9	2.86	1500	3000
SE09G	850	12.2	0.871		0.77	7.7	5.41	1500	3000
SE13G	1300	17.7	0.857		0.47	5.2	8.27	1500	3000
SE17G	1700	23.1	0.88		0.30	3.8	10.82	1500	3000
SE03M	300	6.8	0.1217		3.44	30.5	2.86	1000	2000
SE06M	600	12.2	0.1454		1.88	20	5.72	1000	2000
SE09M	900	17.6	0.1557		1.4	15.9	8.59	1000	2000
SE12M	1200	23.1	0.1568		0.87	10.6	11.46	1000	2000

APM-SF

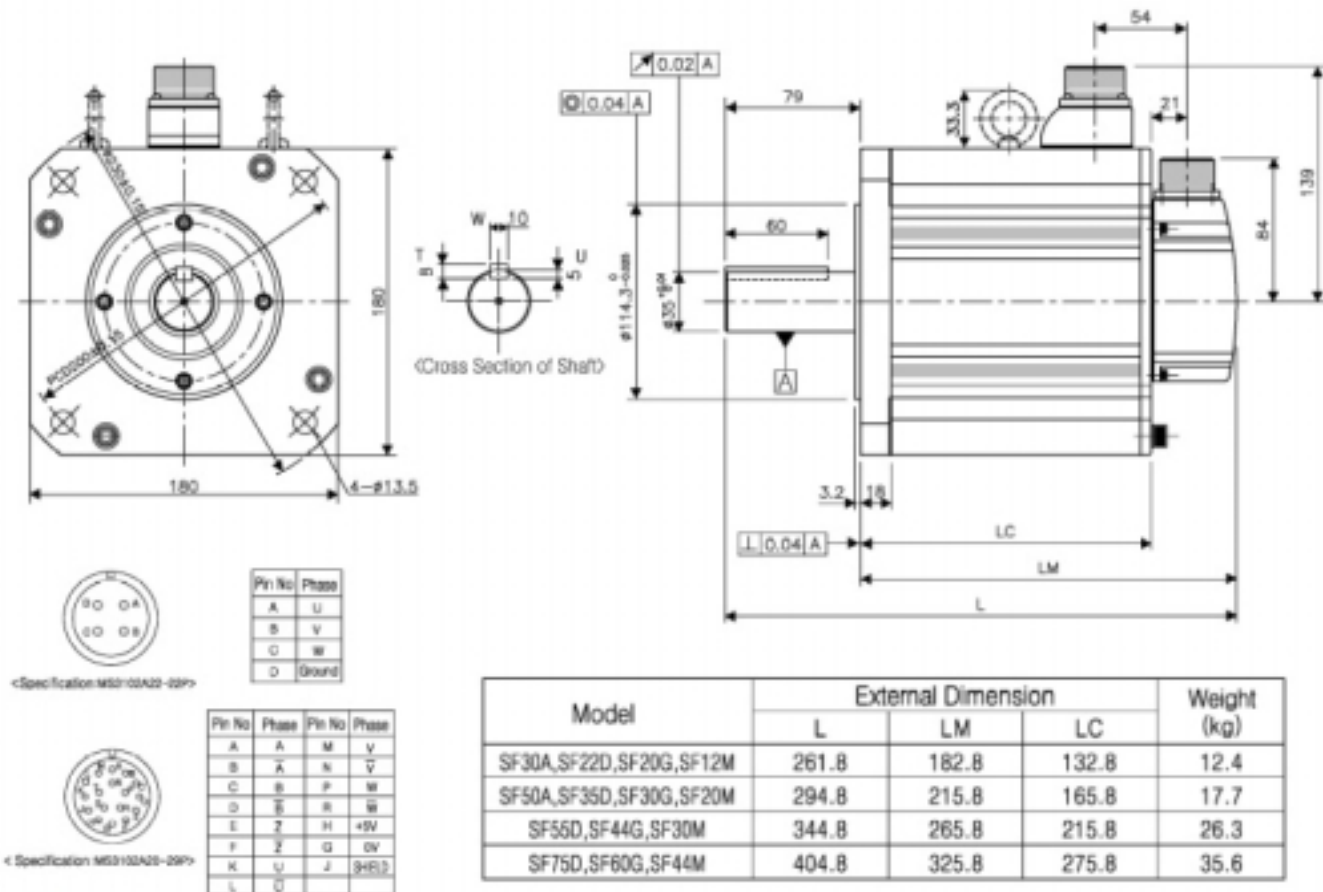

Model	External Dimension			Weight (kg)
	L	LM	LC	
SF30A,SF22D,SF20G,SF12M	261.8	182.8	132.8	12.4
SF50A,SF35D,SF30G,SF20M	294.8	215.8	165.8	17.7
SF55D,SF44G,SF30M	344.8	265.8	215.8	26.3
SF75D,SF60G,SF44M	404.8	325.8	275.8	35.6



Note) I-Bolt is to be used for the models that are SF55D, SF44G, SF30M and higher than those models.

Model	Power Watts	Jm Kgcm ²	Kt Nm/Arms	Ke V/krpm	R	L mH	Tc Nm	Rated Speed rpm	Maximum rpm
SF30A	3000	31.35	0.616		0.11	1.7	9.55	3000	5000
SF50A	5000	53.16	0.626		0.05	0.9	15.91	3000	5000
SF22D	2200	31,35	0.84		0.21	3.2	10.5	2000	3000
SF35D	3500	53.16	0.93		0.11	2.0	16.7	2000	3000
SF55D	5500	85.24	0.922		0.06	1.14	26.25	2000	3000
SF75D	7500	123.7	0.1094		0.05	1.12	35.8	2000	2500
SF20G	1800	31.35	0.822		0.21	3.2	11.45	1500	3000
SF30G	2900	53.16	0.933		0.11	2.0	18.46	1500	3000
SF44G	4400	85.24	0.93		0.11	1.14	28.0	1500	3000
SF12M	1200	31.35	0.143		0.57	8.2	11.46	1000	2000
SF20M	2000	53.16	0.138		0.24	4.5	19.09	1000	2000
SF30M	3000	85.24	0.147		0.13	2.8	28.64	1000	2000
SF44M	4400	123.74	0.139		0.08	1.8	42.2	1000	2000

8 pole

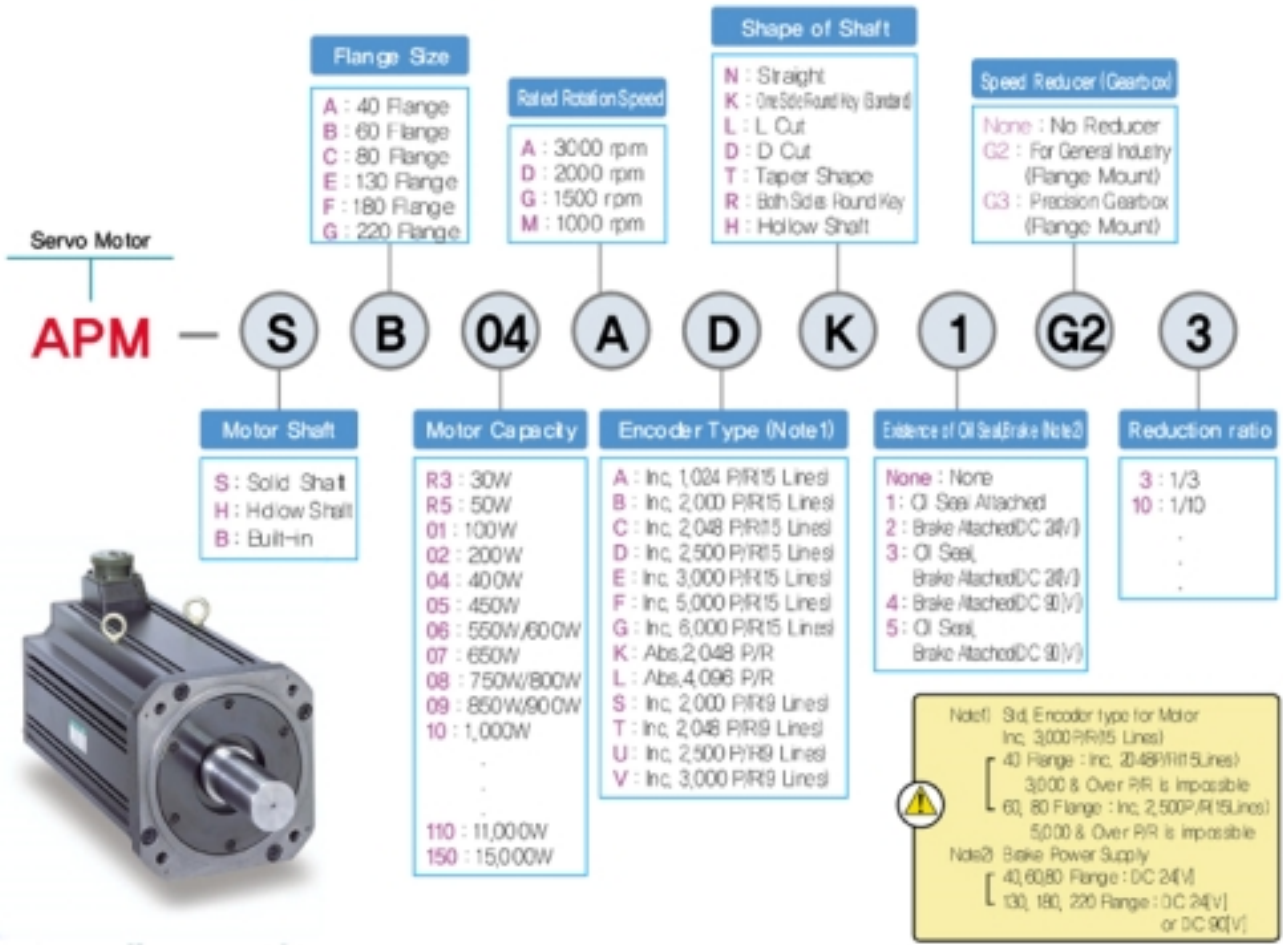

Pin No	Phase
A	U
B	V
C	W
D	Ground



Pin No	Phase	Pin No	Phase
A	A	M	V
B	\bar{A}	N	\bar{V}
C	B	P	W
D	\bar{B}	R	\bar{W}
E	Z	H	+5V
F	\bar{Z}	G	0V
K	U	J	SHIELD
L	\bar{U}		

XTL Xenus Wiring

